

Blis Safe

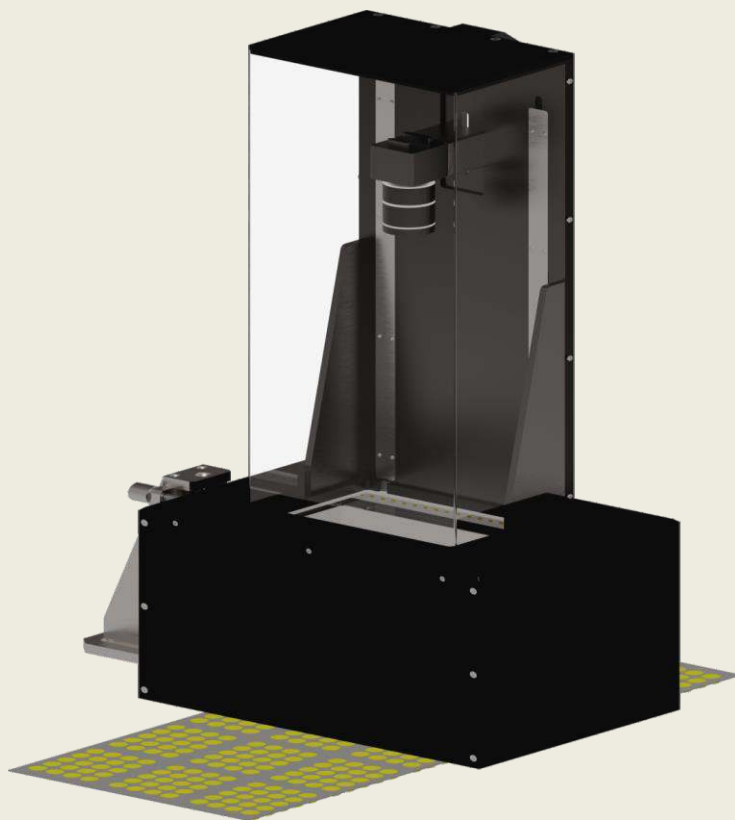

Blister Inspection System

HW+ SW
1 Hand

ROBUST
Algorithm

For A Wide Range
Of PRODUCTS



Quick Setup

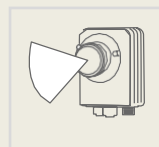

Advance Illumination

FEATURES

- 15" Touch screen with a user-friendly multilingual user interface
- Compact design to fit in all types of blister packing machines (Intermittent / Continuous type) High-resolution and high-speed camera along with customized optics
- State of the art reflection-free white LED based illumination suitable for all types of products Intelligent inspection software with strong and robust algorithm to detect different types of defects for Tablets / Capsules / Caplets on different forming layers
- Auto teach function to teach the product within 1 minute
- Inspection with each track rejection signal output



FEATURES

- Max format area: 350 x 150 mm
- 4 user levels & role management – Administrator, Supervisor, Operator & QA
Various statutory reports like audit trail, product / batch wise non-editable reports Meets 21 CFR part 11 compliance
- Synchronized blister rejection unit with blister packing machine with rejection verification sensor

SOLUTION OFFERED

- Missing product (Empty blister)
Wrong shape product
- Spots on products
- Color differences (Bi-color product) Cracked / broken product
Oversized / undersized
- Foreign particles (Fragments)
Detection of unwanted / wrong product
- Incorrect positioning or misalignment of the product
Wrong code / absence of code on foil i.e. wrong foil or print defect on foil



Sirius Vision

info@siriusvision.net | www.siriusvision.net